

Chapter 3: Rescue Knots and Hitches

Scope: This chapter serves as an introduction to rescue knots and hitches.

Terminal Learning Objective (TLO): At the end of this chapter, the student will be able to identify and properly tie a small number of knots that perform a variety of functions.

Enabling Learning Objectives (ELO):

1. Define the qualities of a rescue knot
2. Define rope terminology
3. Describe the components of knots and hitches
4. Demonstrate how to tie the six required knots

Perhaps the most basic of skills for a rescuer is the ability to tie knots. Rescue knots are a key link to rope rescue systems. Rescue personnel must continually practice and develop knot-tying skills until they can tie knots properly in the most adverse of conditions. An improperly tied knot or the incorrect knot could result in system failure.

Although there are many options of knots to choose from, a rescue team should rely on a small number of knots that perform a variety of functions. Knots should be standardized so everyone on the team can readily identify and safety-check them.

In an effort to standardize terminology, this unit will attempt to use the current name for each knot, but acknowledges that there are many different names for the same knot. Oftentimes, a region or group will determine the standard term for a given area.

Knots should be untied or loosened before storing when practical. Knots that have been used to form permanent components such a prusik loops and stokes litter prerigs would not be practical to untie or loosen.

Qualities of a Rescue Knot

Five characteristics apply to any preferred rescue knot:

1. Easy to tie.
2. Easy to identify if tied correctly.
3. Relatively easy to untie after loading.
4. Minimally reduces the strength of the rope.
5. Won't work loose when not under a load.

Rope Terminology

- The **running end** of a rope is the part that "runs" away from the knot.
- The **working end** of a rope (also known as the loose end or bitter end) is the part used in forming a knot.
- The **standing part** of a rope is between the working end and the running end.

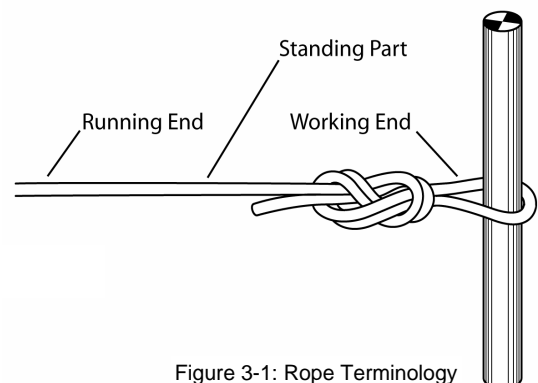

Figure 3-1: Rope Terminology

Components of Knots and Hitches

All knots and hitches can be tied or formed by combining these three components.

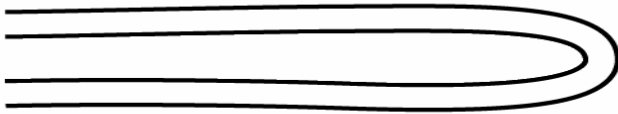

Figure 3-2:

A **bight** is formed by bending a rope back on itself while keeping the sides parallel.

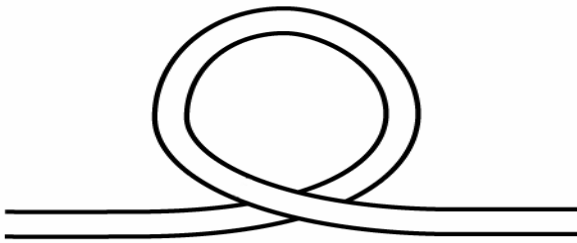

Figure 3-3:

A **loop** is formed by crossing one side of the bight over the other, keeping the sides parallel and in opposite directions.

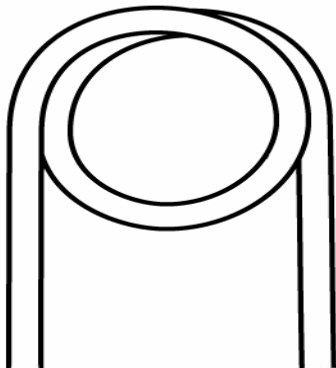

Figure 3-4: Round

A **round turn** is formed from a loop by continuing to cross one side of the loop all the way around an object to form a circle with the ends of the rope parallel as in a bight.

Hitches

Hitches can be used to temporarily secure objects. For example, securing equipment to haul aloft (a clove hitch and half hitches) or securing a victim to a rescue litter (round turn and two half hitches).

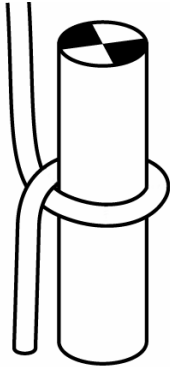

Figure 3-5: Half Hitch from the Loop

A **half hitch** can be formed from a loop that is wrapped around an object with one end crossing over the other and placed under tension.

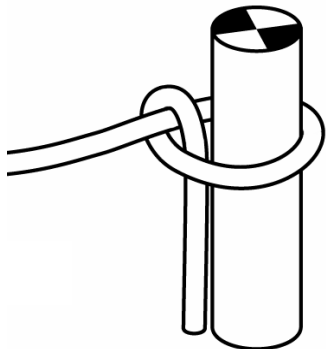

Figure 3-6: Half Hitch on the Loop

A **half hitch** can also be formed on the loop itself.

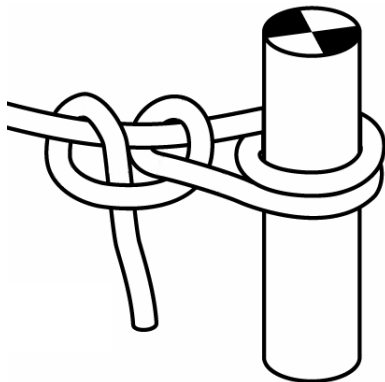

Figure 3-7: Round Turn and Two Half Hitches

A common application is a **round turn and two half hitches**. This combination allows the rescuer to increase tension on the line or webbing with the round turn and then to secure that tension with the two half hitches.

Knots

A **knot** is a combination of components: bights, loops, and round turns. The combination that is used, determines the specific knot that is constructed.

A **bending knot** (overhand bend, figure eight bend, double overhand bend) is used to tie rope or webbing into itself to form a continuous loop, or to join two lengths of material together to extend the length.

Proficiency in six knots is required for this course. These are the "need to know" or required knots for this class. Most low angle rescues can be performed with these knots. An additional six (6) knots have been identified as "nice to know" or optional knots. Instructors may add to the list depending on regional needs.

Terminology

All knots must be "dressed" and "set" tightly. "Dressing" a knot means ensuring that any twists or abnormalities are removed from the knot leaving it looking uniform. "Setting" a knot means pulling tension on all strands of the standing portion of the rope and on the tail left on either side of a knot. This removes any slack from the strands of the rope forming a knot, effectively "setting" the knot.

Tail Length

Tail length on knots will vary. **Minimum** tail length for the following materials shall be:

- Figure eight knots and bends in lifeline are 6".
- Double overhand on a bight in lifeline is 2".
- Overhand knots and bends in webbing are 2".
- Half hitches in webbing or rope are 2".
- Double overhand bend in prusik cordage is 1".

The curriculum for Low Angle Rope Rescue does not require that knots be backed up. Many regional rescue teams require that all knots shall be backed up with additional overhand knots formed with the tail of the rescue knot. In these instances, a longer tail will need to be left once the rescue knot is tied, dressed, and set to provide enough material to tie the back up knots.

Required Knots

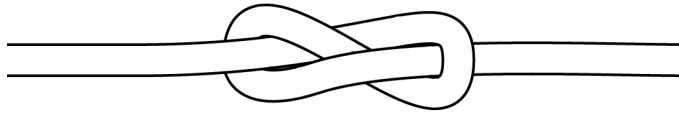

1. Figure Eight Stopper

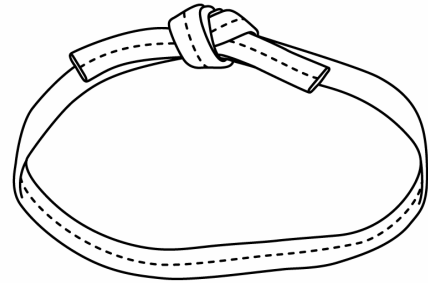

4. Overhand Bend

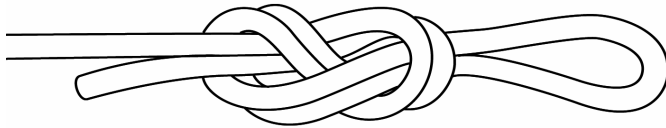

2. Figure Eight on a Bight

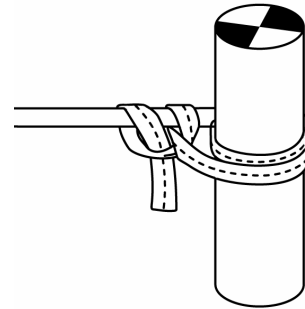

5. Round Turn with Two Half Hitches

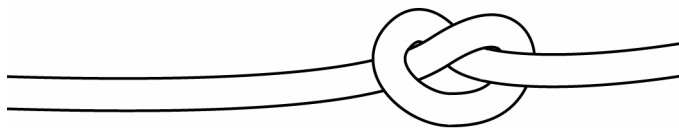

3. Overhand Knot

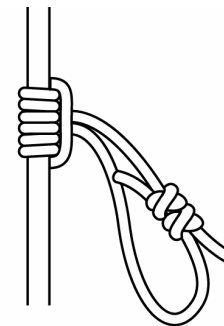

6. Three Wrap Prusik Hitch

Optional Knots

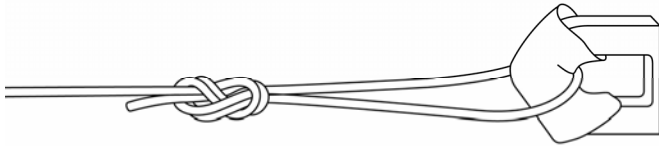

1. Figure Eight Follow Through

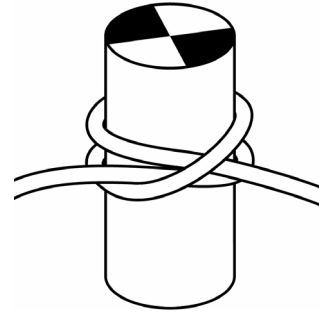

4. Clove Hitch



2. Figure Eight Bend



5. Double Overhand on a Bight



3. Double Overhand Bend

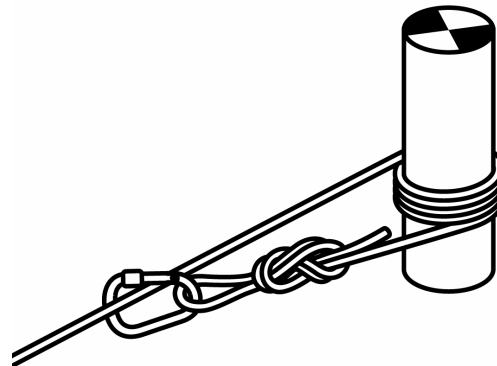

6. Tensionless Hitch

1. Figure Eight Stopper (Required)

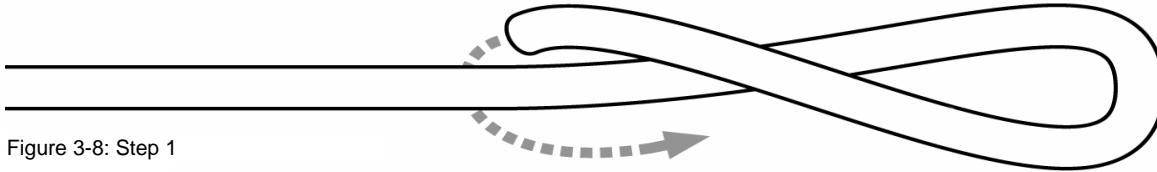

Figure 3-8: Step 1

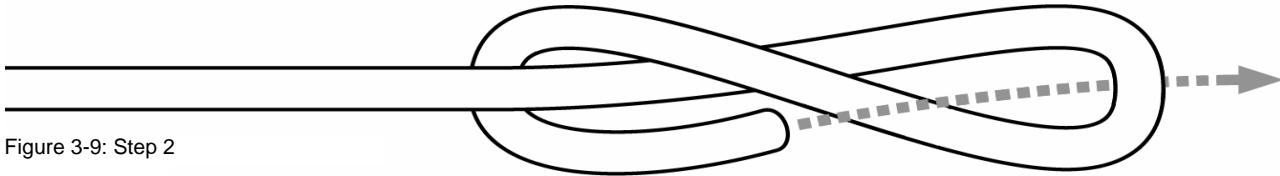

Figure 3-9: Step 2

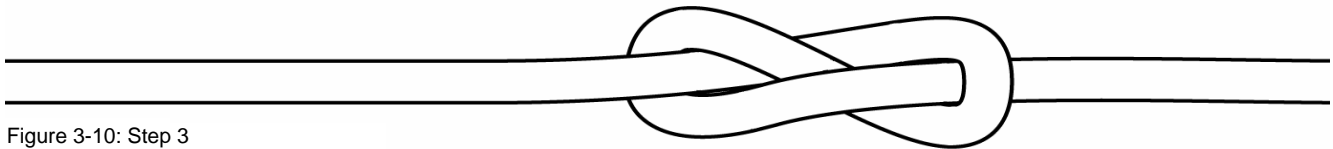

Figure 3-10: Step 3

Use

- Indicator of the end of the rope.
- Keep rope from pulling through a system or hands.
- Stop rope against a component in the system.
- Foundational knot for the rest of the family of eight knots

Specifics

- Tail length is dictated by use.
 - If used as an indicator of the end of the rope, leave enough rope to tie into a new system.
 - Generally 6".
- Dressed and set.

2. Figure Eight on a Bight (Required)

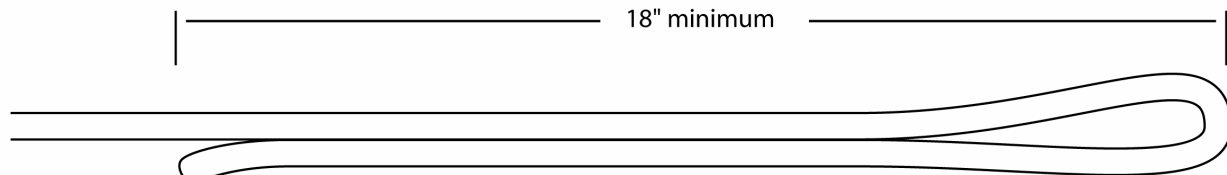

Figure 3-11: Step 1

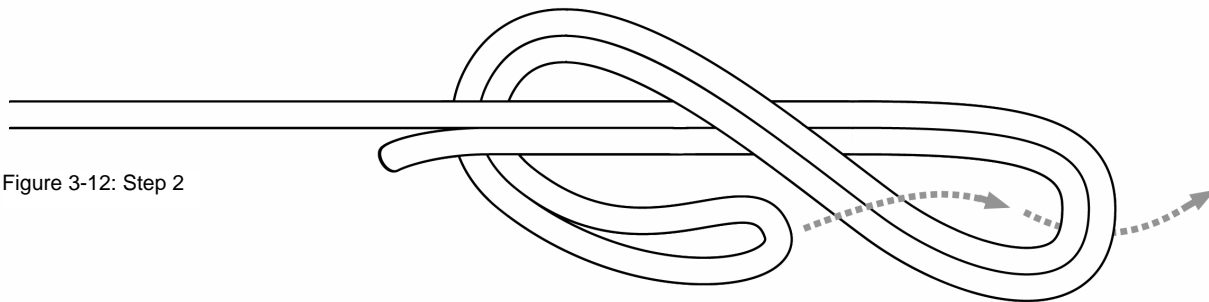

Figure 3-12: Step 2

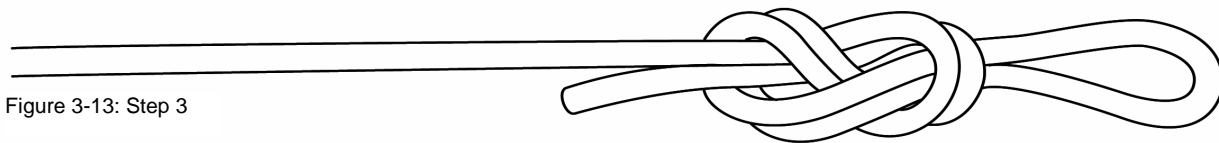

Figure 3-13: Step 3

Use

- Form a secure loop in lifeline that can be attached to system components with a carabiner.
- Attach main lines and safety lines to:
 - Litters.
 - Anchors.
 - Rescuers.
 - Victims.

Specifics

- 6" tail (minimum).
- The length of the bight is determined by the use of the knot.
 - When attaching into a single point (i.e., pelvic harness), the bight should be 4".
 - When attaching into two points (i.e., pelvic and chest harness), the bight should be 6"-10".
 - When maximum length or availability of the line is needed, the bight should be kept 1"-2" in length.
- Dressed and set.

3. Overhand Knot (Required)

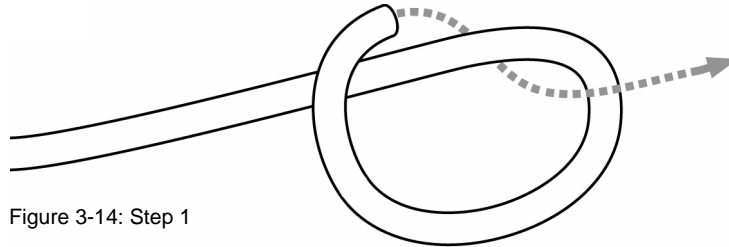

Figure 3-14: Step 1

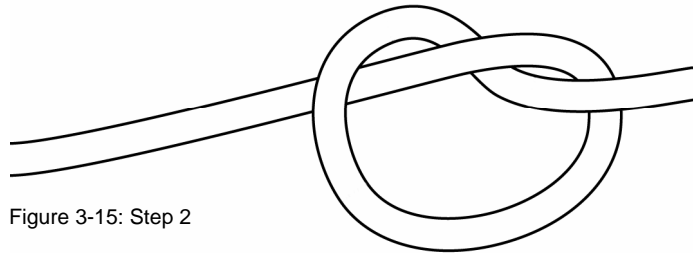

Figure 3-15: Step 2

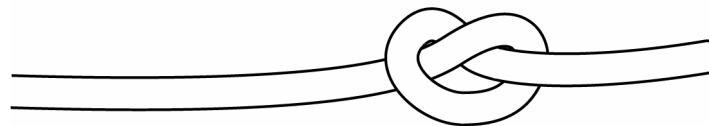

Figure 3-16: Step 3

Use

- Used on the tails of other knots (e.g., figure eight on a bight).
- Secure or take up loose or long ends in lifeline or webbing (e.g., excessive tail on a round turn with two half hitches).
- Can be used in place of half hitches.

Specifics

- 2" tails (minimum).
- Should be tied cleanly without twists in the webbing.
- Forms the foundation of the overhand bend.
- Dressed and set.

4. Overhand Bend (Required)

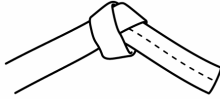

Figure 3-17: Step 1

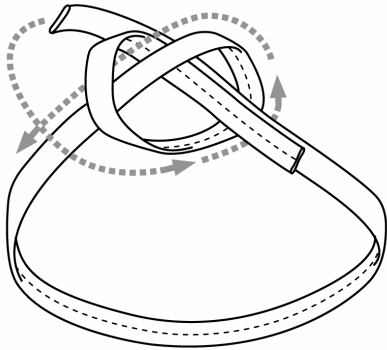

Figure 3-18: Step 2

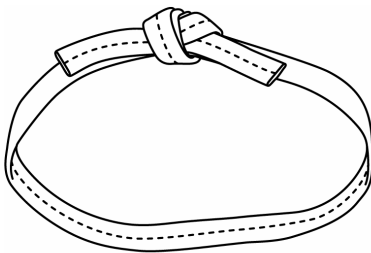

Figure 3-19: Step 3

Use

- Primary knot used in webbing to form a continuous loop.
- Join two pieces of webbing together to increase length.

Specifics

- 2" tails (minimum).
- Knots should be tied cleanly without twists in the webbing.
- Can be difficult to untie once loaded.
- Dressed and set.

5. Round Turn and Two Half Hitches (Required)

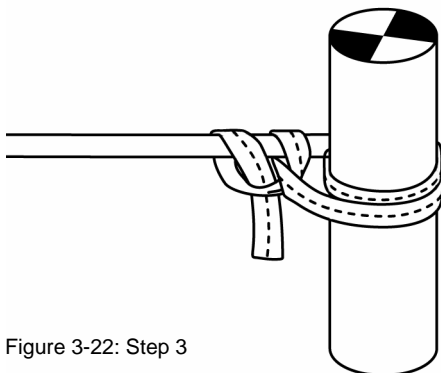
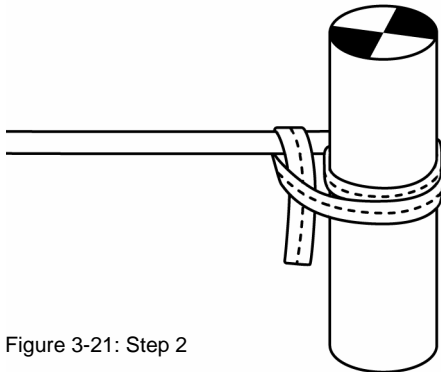
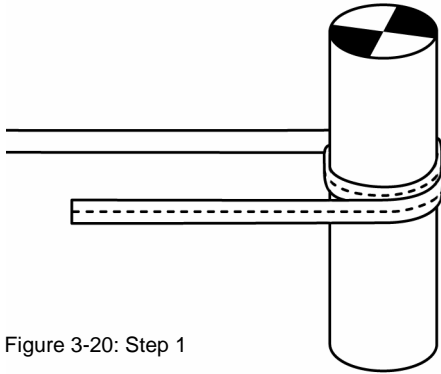

Use

- Secure webbing or lifeline to an object.
 - Rescue litter.
 - Ladder rung.
 - Picket.

Specifics

- 2" tails (minimum).
- Should be tied cleanly without twists in webbing.
- Some rescue teams substitute two overhand knots for the two half hitches.
- Dressed and set.

6. Three Wrap Prusik Hitch (Required)

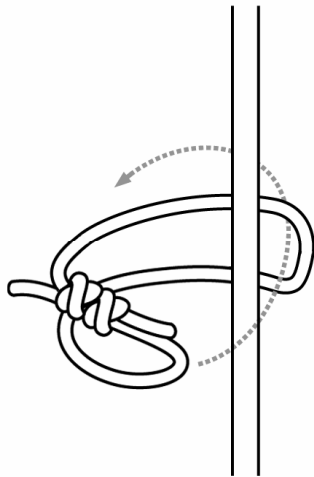

Figure 3-23: Step 1

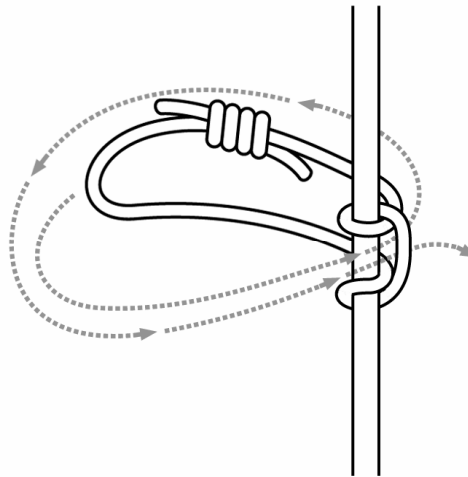

Figure 3-24: Step 2

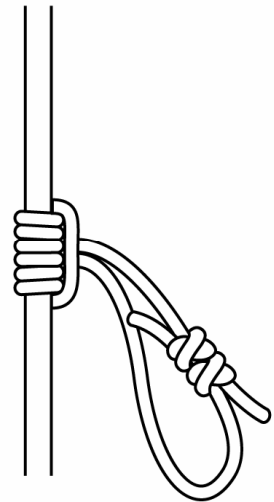

Figure 3-25: Step 3

Use

- Attach a prusik loop to a lifeline, forming a hauling, ratchet, or braking cam.

Specifics

- Use prusik loop made from 8mm cordage.
- The double overhand bend used to form the prusik loop should be positioned so that it does not interfere with the clipping point of the carabiner.
- The wraps of the prusik should be even and smooth.
- Some rescue teams utilize the "quick release" variation of the three-wrap prusik hitch.
 - Double overhand bend is positioned over the wraps of the prusik hitch.
- Contact the lifeline manufacturer to identify compatible cordage for the specific lifeline.
- Dressed and set.

1. Figure Eight Follow Through (Optional)

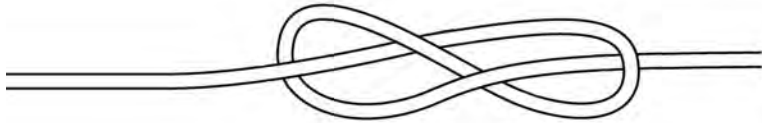

Figure 3-26: Step 1

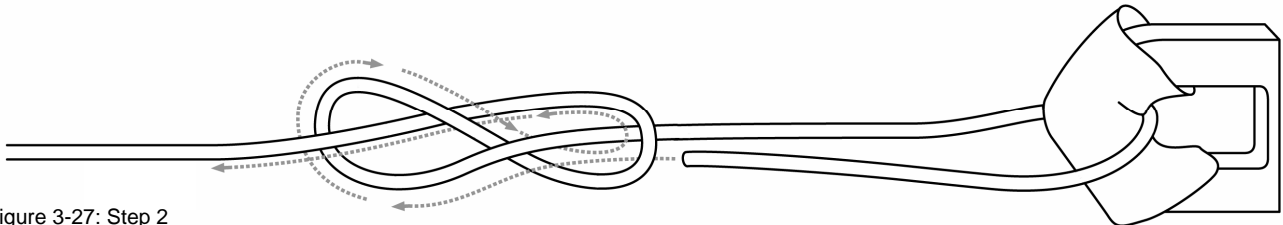
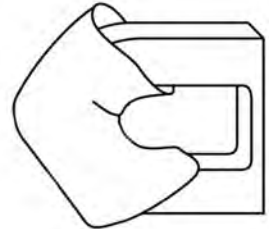

Figure 3-27: Step 2

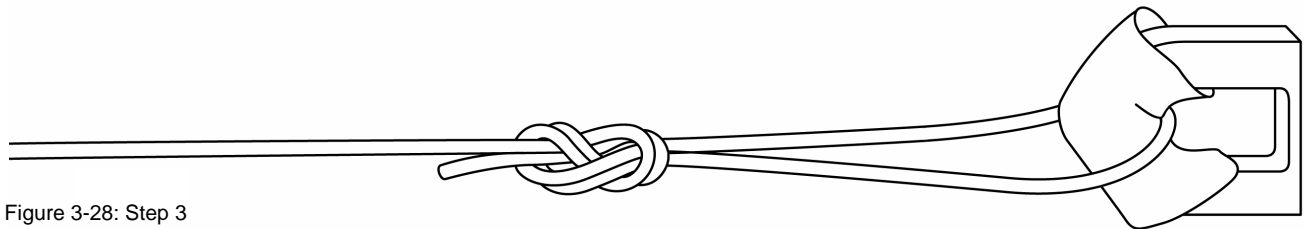

Figure 3-28: Step 3

Use

- Secure lifeline around an object such as a tree.
- Secure lifeline through a "trussed" anchor such as a closed tow hook on a fire engine.

Specifics

- 6" tail (minimum).
- Chaffing protection may be needed.
- Difficult to untie after loading.
- Dressed and set.

2. Figure Eight Bend (Optional)

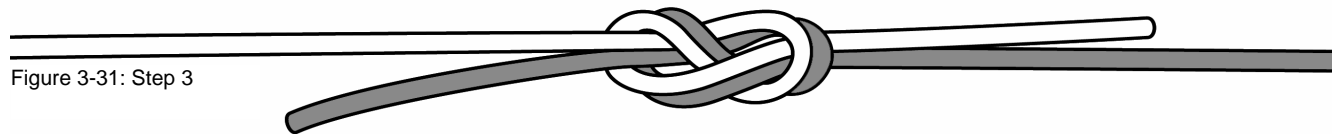
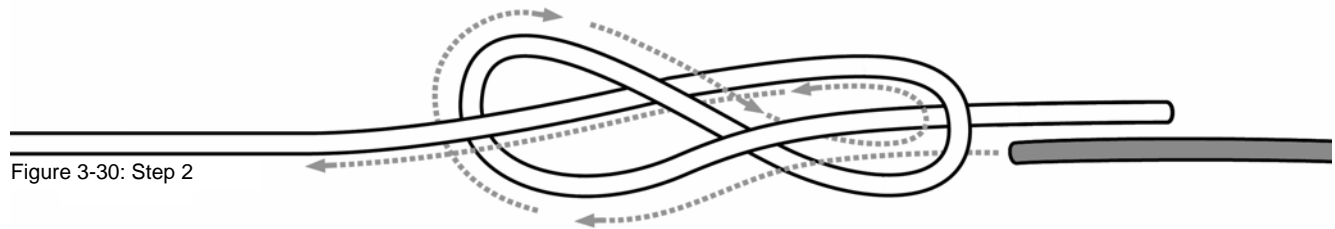
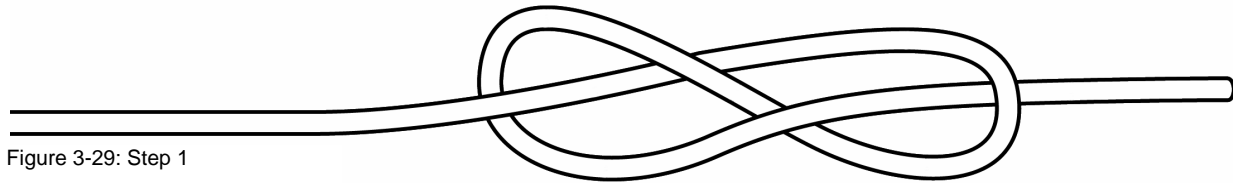

Use

- Join two lifelines of the same diameter together.
- Tie one length of lifeline into a loop.

Specifics

- 6" tail (minimum).
- Difficult to untie after loading.
- Dressed and set.

3. Double Overhand Bend (Optional)

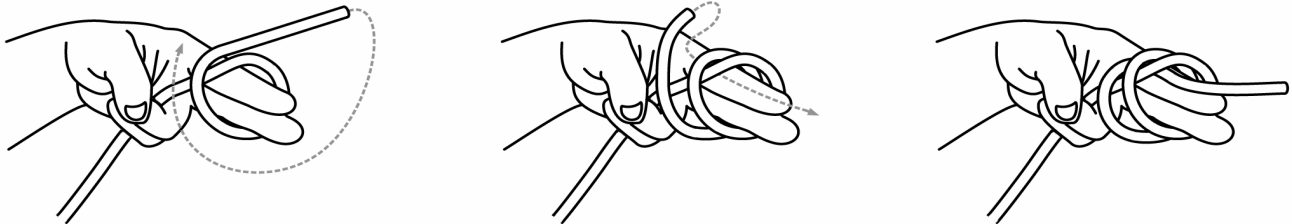

Figure 3-32

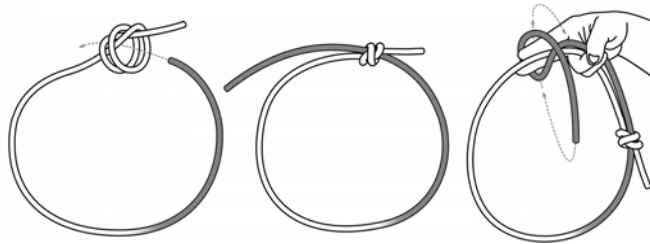

Figure 3-33

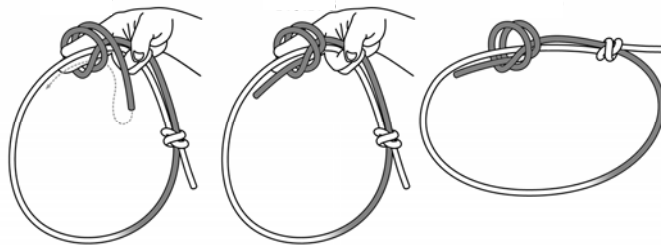

Figure 3-34



Figure 3-35

Use

- Tie two equal diameter ropes ends together.
- Preferred knot for tying prusik loops.

Specifics

- 1" tails (minimum).
- When tied correctly, the tail of each rope should end up on the side of the knot opposite the side it entered.
- The two turns from each half of the knot should lie flat against one another on one face of the knot and appear as a double X on the other side.
- Difficult to untie once loaded.
 - It is for this reason that once tied, prusik loops are not generally untied until damaged or retired.
- Dressed and set.

4. Clove Hitch (Optional)

Method 1: Slid Over the Open End of an Anchor

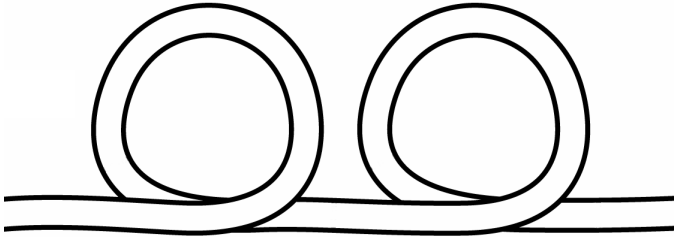

Figure 3-36: Step 1

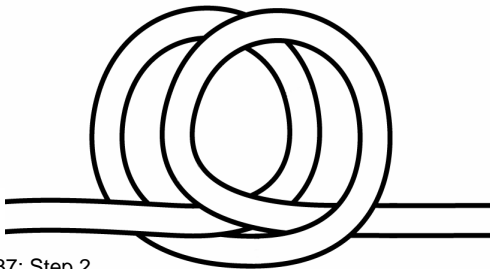

Figure 3-37: Step 2

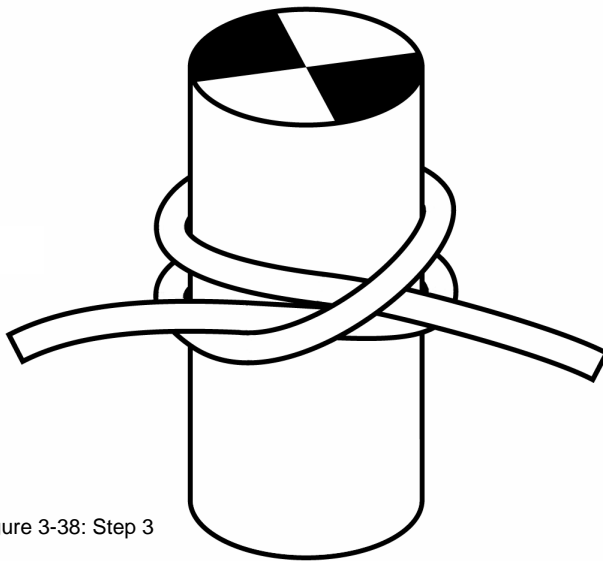

Figure 3-38: Step 3

Use

- Secure webbing or lifeline to a round, nontrussed anchor.
 - Picket.
 - Bullard.
- Used when the hitch can be slipped over one end of an anchor.

Specific

- 4" tail (minimum).
- Often backed up with one overhand knot or two half hitches.
- Dressed and set.

Method 2: Tied Around a Trussed Anchor

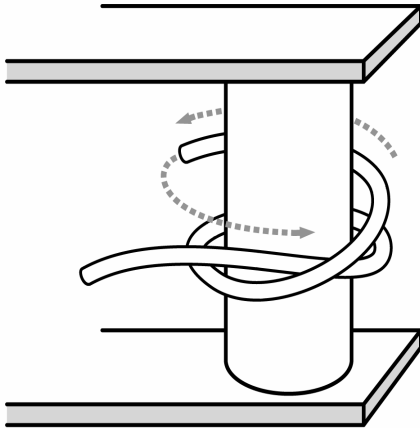

Figure 3-39: Step 1

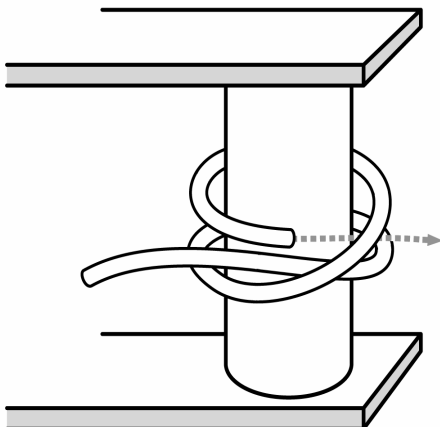

Figure 3-40: Step 2

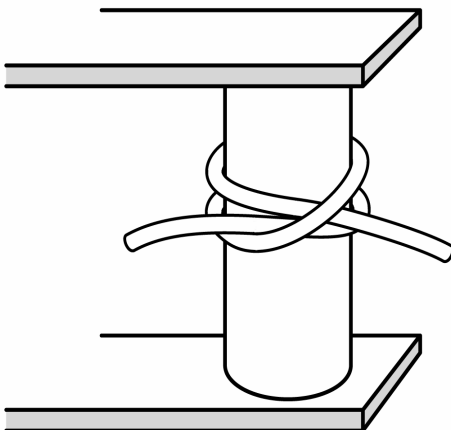

Figure 3-41: Step 3

Use

- Secure webbing or lifeline to a round, trussed anchor.
 - Litter rail.
 - Ladder rung.
 - Tree.
- Used when the hitch *cannot* be slipped over one end of an object.

Specifics

- 4" tail (minimum).
- Often backed up with one overhand knot or two half hitches.
- Dressed and set.

5. Double Overhand on a Bight (Optional)

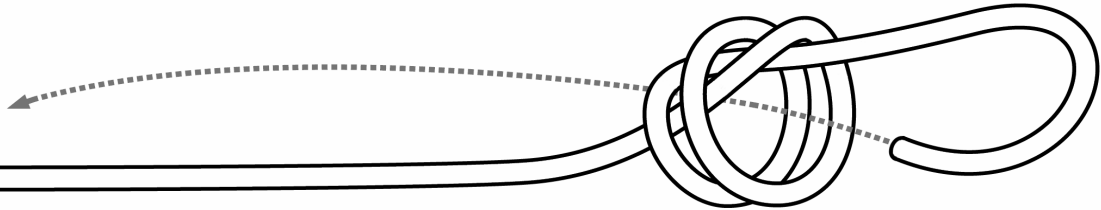

Figure 3-42: Step 1

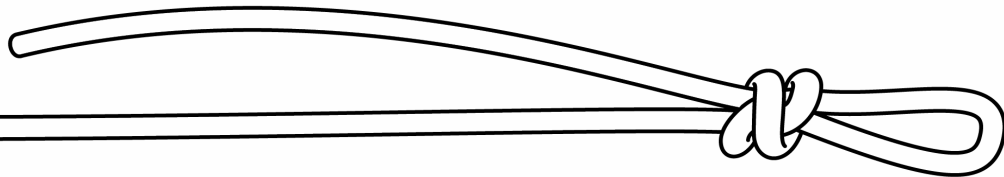

Figure 3-43: Step 2

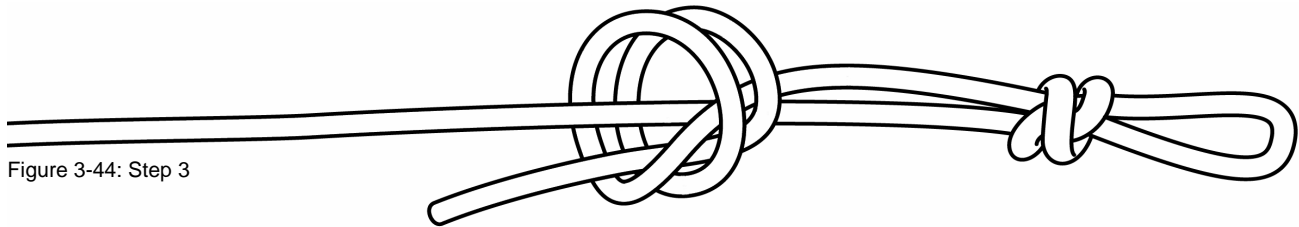

Figure 3-44: Step 3

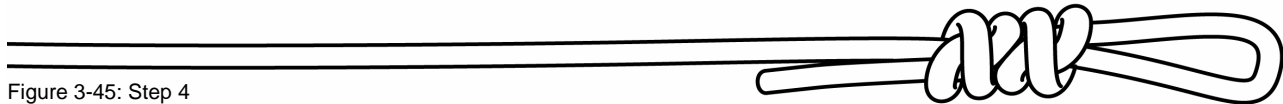

Figure 3-45: Step 4

Use

- Provide permanent bight or loop at the end of a rope or lifeline.
- Commonly used to replace the figure eight on a bight at the ends of prerigs.

Specifics

- 2" tail minimum.
- Once loaded, will not come undone.
- Very difficult to untie.
- Dressed and set.

6. Tensionless Hitch (Optional)

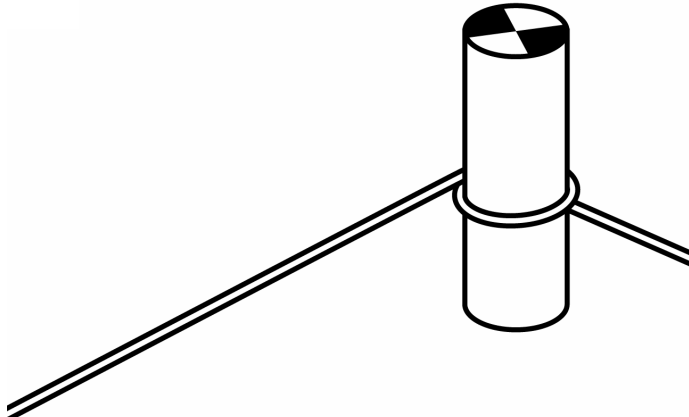

Figure 3-46: Step 1

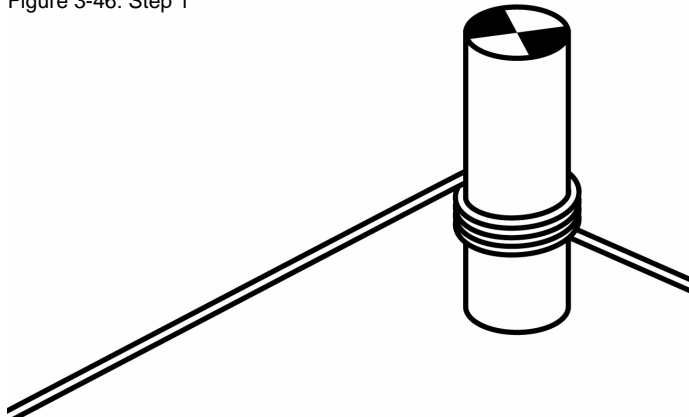

Figure 3-47: Step 2

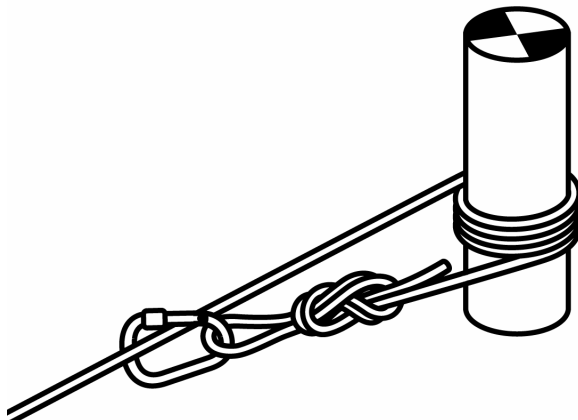

Figure 3-48: Step 3

Use

- Simple method to anchor a rope to a round anchor point.

Specifics

- Derives its name from the fact that the standing end of the lifeline does not have any tension in it when the working end is pulled on.
- Can preserve up to 100% of the strength of the lifeline.
- The number of wraps depends on the smoothness of the anchor.
 - The smoother the surface, the more wraps that will be needed.
 - Between 4-6 wraps.
- Using a round anchor less than 4" in diameter will result in a reduction in the strength of the lifeline.
- The lifeline is tied to the standing end of the lifeline as a safety measure using an overhand knot or secured with a carabiner.
- While this is an extremely strong way to anchor a lifeline, it can use a significant portion of the length of lifeline.
 - This shortening of available lifeline length must be considered before this anchor is used in a system.
- Dressed and set.